

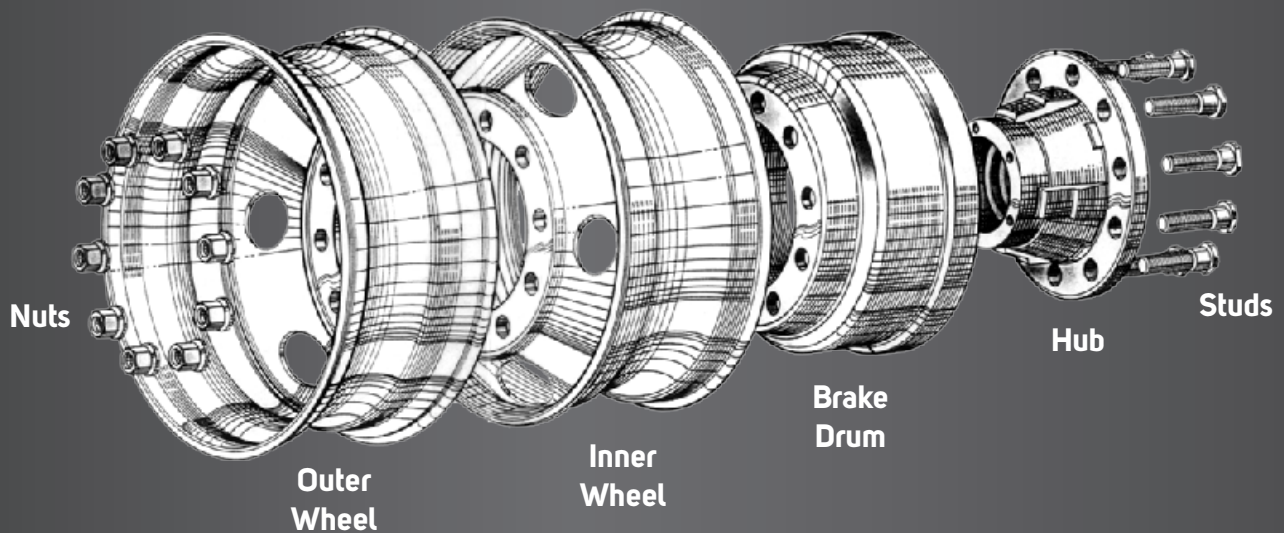

Best Practice for Wheel Torque and Clamping Force



Preventing loose and cracked wheels and wheel end components

Is Improper Maintenance Putting Your Fleet at Risk?

We could easily overlook the vital role that studs, nuts, and proper torque play in the life of wheels, drums, hubs and other wheel end components. Over torque and insufficient torque are the most common root causes of loose and cracked wheels and wheel end components.

Lack of basic maintenance can lead to cracks and failure, causing accidents, lost loads and, potentially, even injury. Yet these hazards are entirely preventable with proper maintenance. Learning how to recognize and prevent loose torque conditions is paramount for achieving the maximum life of wheels and wheel end components. The following information – together with the Accuride Rim/Wheel Safety and Service Manual – will help you do so.

Is your fleet maintaining optimal clamping force conditions on your wheel end components?

Loose Torque vs. Over Torque

When properly maintained, wheels should last the life of the vehicle. Assuring that your wheels stay properly clamped is the key to avoiding early fatigue in wheel end components.

Commercial vehicles operating under the Federal Motor Carrier Safety Regulations (FMCSRs) must meet the Compliance Safety Accountability (CSA) program. Cracked wheels, rusty components, loose or missing wheel fasteners, and elongated or broken studs all represent potential violations under the driver safety measurement system. To avoid them, it is essential to maintain the proper clamping force.

Lack of inspection and routine maintenance, not following the manufacturer's instructions, mismatched parts and loose or over-torqued nuts are the main causes of losing proper clamping force on wheels and wheel end components.

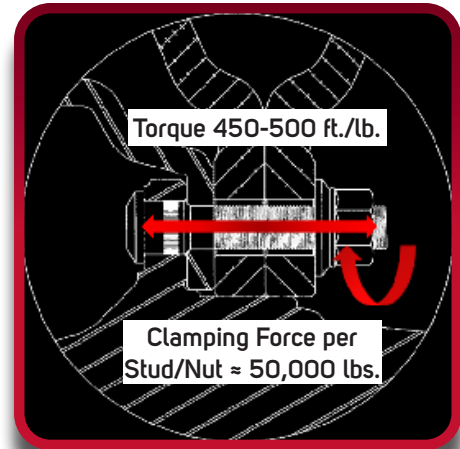

- The ideal clamping force is achieved and maintained through the use of new fastening components that are applied using the manufacturer's specific torque and re-torque practice criteria (see chart on next page).
- If any one of the stud/nut combinations loses its clamping force, the load forces are redistributed over the remaining studs/nuts. This causes the adjacent nuts to fatigue.
- Insufficient clamping force may create "play" in the wheel. This can increase stress loads on the wheel and other components that lead to fatigue cracks, deformed stud holes, stud damage and, potentially, wheel loss.
- A common misconception in the industry is to correct low clamping force by over torque. This practice can stretch the stud beyond its yield point, rendering it ineffective.
- The proper preventive maintenance practice is for drivers and mechanics to periodically inspect wheels and wheel end components. This makes it possible to identify and address issues at an early stage, before damage occurs.
- Inspecting a wheel's back-up diameter during tire and brake changes may reveal a scalloped back-up diameter. This indicates low clamping force within the wheel end. Ensure that all mounting surfaces, studs, and nuts are properly cleaned and oiled as described in the Safety and Service manual before the wheel is reinstalled.

What Can Cause Loose Wheel Conditions?

- Excess paint, rust, scale, or dirt between mating areas of wheel end components. All components must be in good working condition.
- Incorrect use of wheel, nut, and stud components.
- Failure to follow the manufacturer's instructions for specified torque, the correct tightening sequence, and routine in-service torque checks.
- Improper use of impact and non-calibrated tools. Studs stretched beyond their yield point, fractured or worn out nuts with deformed threads that result in insufficient clamping force.

The condition of the studs and nuts has a direct impact on the level of torque that can be achieved.

(Study was done by using an M22 x 1.5 stud and two piece flange nut)

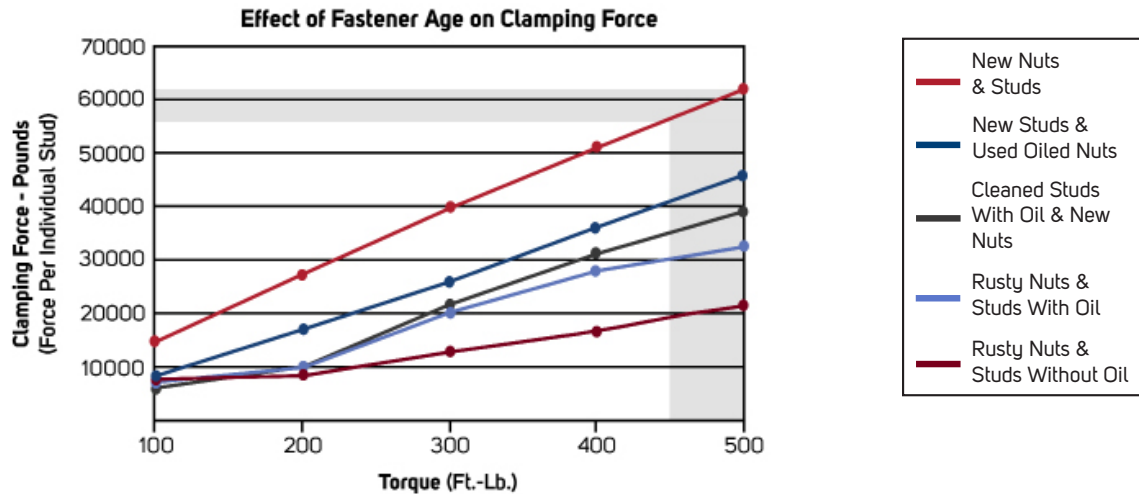

Too Much Paint Can Impair Torque Retention

The maximum allowable paint thickness is .0035 inches (3.5 mils), which is about the thickness of a magazine page. If you cannot read the stamping, there is too much paint applied. **Such wheels should be repaired before being reinstalled on the vehicle.**



Paint thickness gauge reads 16.68 mils, above the maximum allowable thickness of 3.5 mils.



Visible signs that paint exceeds the maximum allowable thickness of 3.5 mils. Multiple coats, uneven surfaces, and illegible stampings indicate too much paint.

If wheels are installed with excessive paint thickness, debris, or excessive corrosion, the paint, debris, and corrosion will gradually work its way out during operation.

This could cause the wheel to lose clamping force and could result in cracked or broken wheels, damaged brake drums, broken studs, and wheel separation from the vehicle.

Thick paint and debris works out while vehicle is being driven.

Thick Paint and Debris

Thick paint and debris works out while vehicle is being driven.

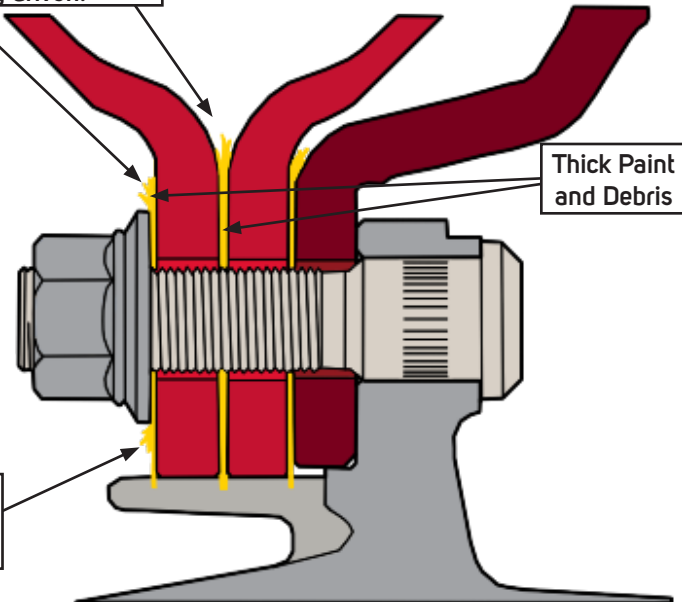



Wheel Failures Related to Loss of Clamping Force

- Bolt Hole Cracks
- Bolt Hole to Bolt Hole Cracks
- Bolt Hole to Center Hole Cracks
- Walled or Elongated Bolt Holes
- Circumferential Cracks on Mounting Area (for hub-piloted wheels)
- Worn Bolt Hole Ball Seats (for stud-piloted wheels)
- Distorted Bolt Hole Ball Seats (for stud-piloted wheels)
- Burrs Around Bolt Holes (for stud-piloted wheels)
- Broken Studs
- Cracked Flange Nuts
- Cracked or Broken Inner Cap Nuts (for stud-piloted wheels)
- Stripped or Deformed Threads on Studs and Nuts
- Scalloped Witness Mark
- Edge of Nut Crack



Bolt hole crack



Edge of nut crack



Broken stud



Scalloped witness mark

Recommended Practice: Preventing Damage to Wheel End Components on Medium and Heavy Truck, Trailer and Bus Applications

- It is important to pay close attention to wheel studs, and clean and maintain them regularly. Rust and corrosion should be removed from all mounting surfaces on the wheel, hub, drum, and studs. Also remove any burrs on or around the bolt holes and center holes
- For hub-piloted wheel systems, use two to three drops of lubrication – SAE 30 weight or equivalent – on the outer two threads of the stud and a drop between the nut body and flange.
- Torque each two piece flange nut for the following: M22 x 1.5 to 450-500 ft./lb., M20 x 1.5 to 280-330 ft./lb. and M14 x 2.0 to 150-160 ft./lb. Recheck torque levels again after the first 50-100 miles driven. Recheck torque levels regularly at 10,000 mile intervals.
- When checking wheels, look for signs of cracks and rust lines originating from bolt holes. These are common signs of low clamping force.
- If a stud is broken, you must replace the adjacent studs on either side of it. If two or more studs are broken, all studs must be replaced.

Reference TMC RP237 and the Rim/Wheel Safety and Service Manual (W3.000) for additional information regarding torquing and retorquing wheels.

Your only single source for industry-leading wheel end solutions.

STEEL & ALUMINUM WHEELS | DRUMS | HUBS | ROTORS | SLACK ADJUSTERS

For more information: **(800) 823-8332** | accuridecorp.com

Accuride | 7140 Office Circle | Evansville, IN 47715 USA

W1.009 Rev.2 0320 ©2020 Accuride Corporation

