

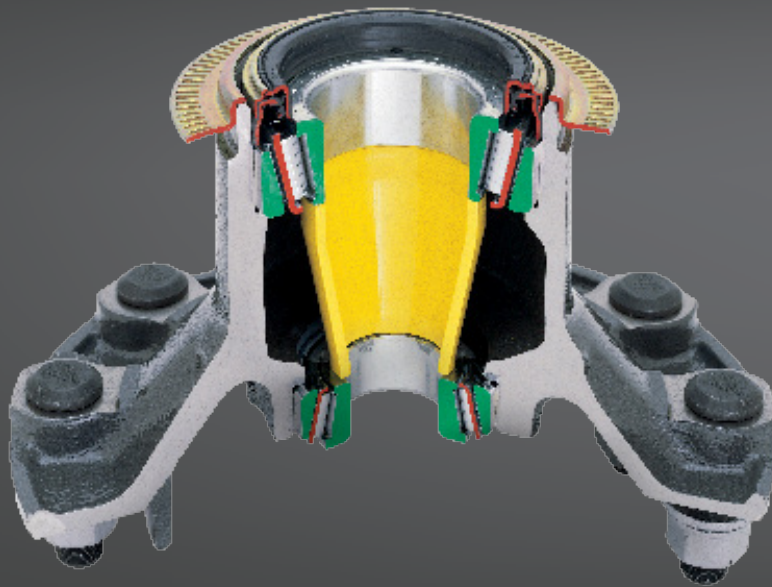

Gunite High Performance Hubs



Maintenance and Installation Manual

Your only single source for industry-leading wheel end solutions.

STEEL & ALUMINUM WHEELS | DRUMS | HUBS | ROTORS | SLACK ADJUSTERS

Gunite High Performance disc wheel hubs are designed using the Gunite Tru-Set® system to provide today's fleets with superior performance, lower maintenance costs and lightweight in a unique unitized design. While these hubs have the same outward appearance as Gunite's conventional hubs the installation and maintenance procedures differ from conventional hubs.

The procedures covered in this manual are for the maintenance and installation of the High Performance hubs. For additional maintenance information on Gunite disc wheel hubs, consult the Gunite Conventional Hub Maintenance Manual.

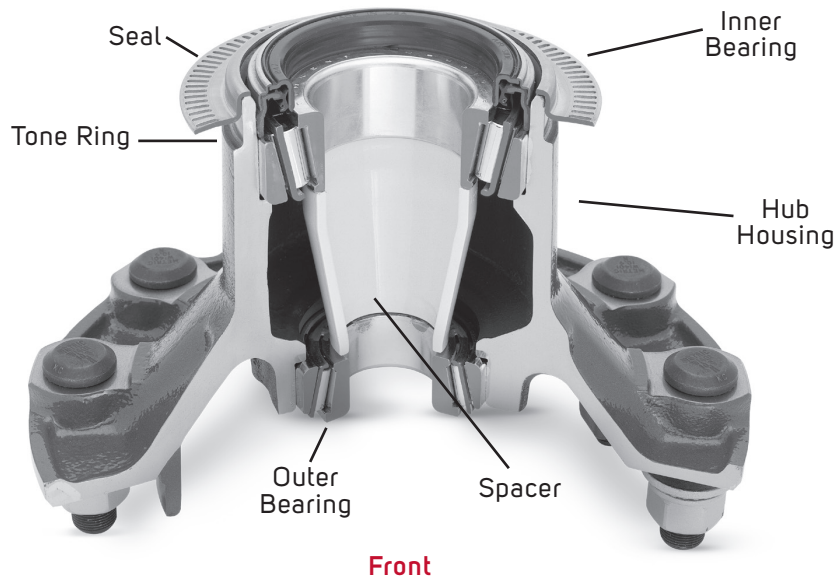

These hubs are factory installed and preloaded to exacting tolerances and are intended to operate without any special maintenance procedures required.

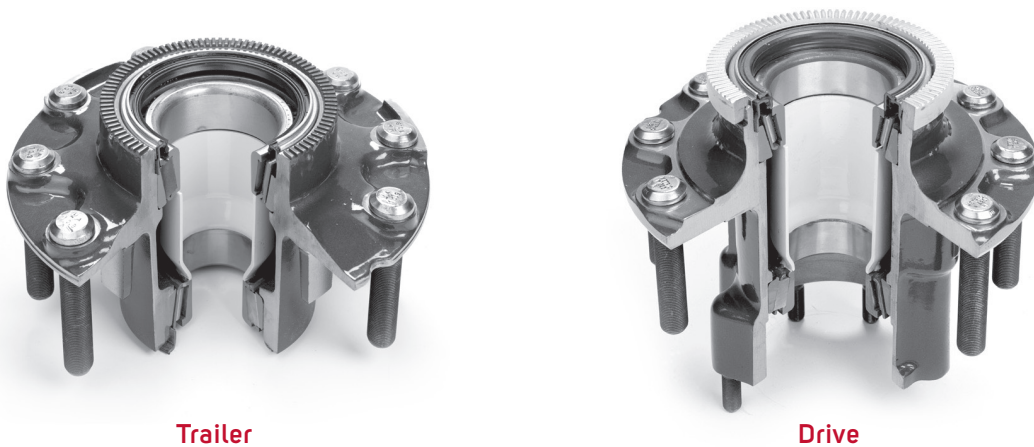

Routine Maintenance

Gunite High Performance hubs are designed to maintain proper bearing adjustment for extended intervals without the need for periodic adjustment. As with any hub, Gunite High Performance hubs should be thoroughly inspected for damage during routine wheel-end-maintenance. Proper levels of lubrication must be maintained and seals checked for leaks.

Installation of a Gunitite High Performance Hub

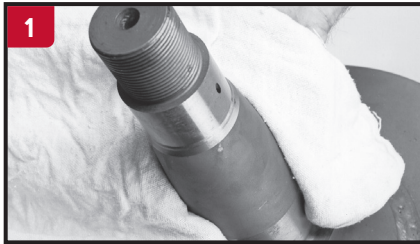

Once the original hub has been removed, clean and wipe dry the axle end.



Remove the replacement hub from the shipping container and remove and discard the plastic retainers holding the Tru-Set® system components in place.

CAUTION

Failure to completely coat the spindle surfaces with lubricant will result in premature corrosion fretting on the bearings and spindle journals.

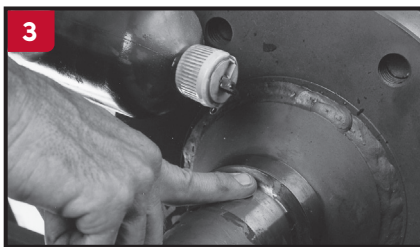

Apply a light film of lubricant to the axle spindle, bearing shoulder, seal journal and seal I.D. For drive axles, use the same lubricant as is used in the axle sump. For steer and trailer axles use the same lubricant that is used in the hub.

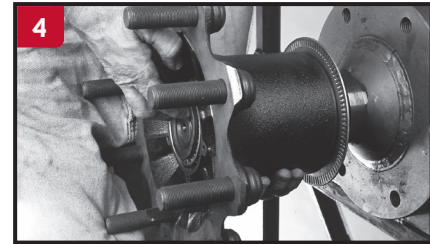

Lift the hub into position and carefully supporting the hub housing align the internal spacer with the axle and guide the hub into position. Press the hub into place making sure that the hub is properly positioned on the bearing journal. **Care must be taken not to damage the seal during installation.**



Once the hub is properly positioned on the axle spindle, the outer bearing is placed in position. Then install the spindle nut(s).

Spindle Nut Installation Procedure - Dual Nut System

Install the inner spindle nut with the dowel pin facing outward. Tighten the spindle nut to 300 ft. lbs. to 350 ft. lbs.

Install the dowel-type washer. If the washer does not align with the dowel pin, turn the washer over. If the washer still does not align with the dowel pin, determine the position in which the washer comes closest to the dowel pin; and tighten the inner nut until the dowel pin is aligned.

Install the flat retaining washer with the dimple facing inward and engaged in a hole.

If a tang style retaining washer is used, engage the inner tang into the spindle key slot. When installed and properly torqued, bend one of the tangs over the outer nut.

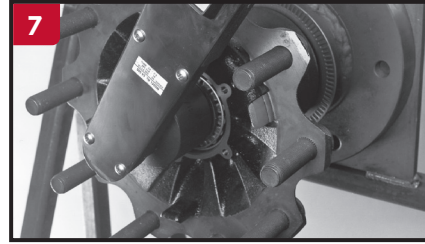
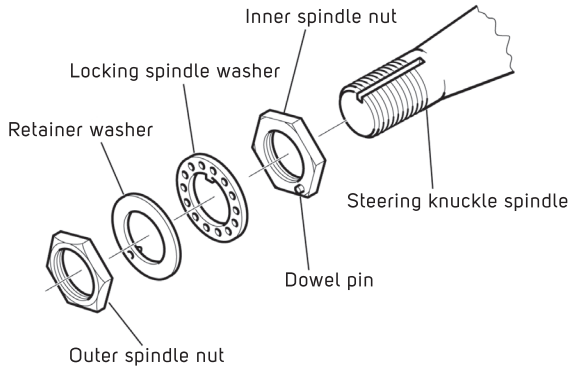

Torque the spindle nut(s) to the proper torque value as stated in step 6.

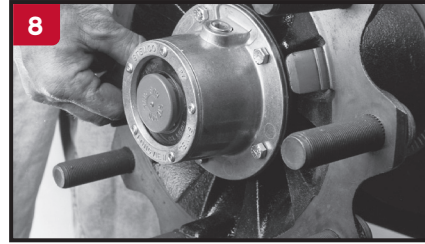

Install the hubcap and fill with lubricant to the prescribed level. (See Lubrication Requirements on page 5.)

NOTE

Some models of the Gunite High Performance hubs for drive axle applications are equipped with an intergal oil fill.

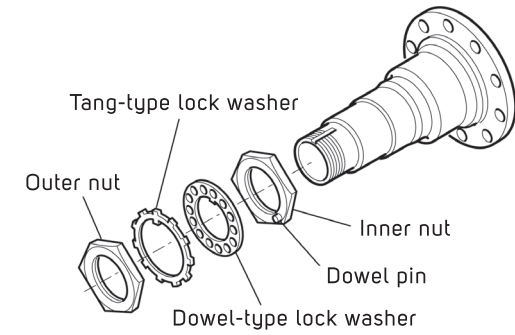

Spindle Nut Installation Procedure - Castellated Nut System

Install the castellated spindle nut and tighten, torquing to 350 ft. lbs. Install the cotter pin. If the cotter pin hole does not align properly with the nut, tighten the nut until the cotter pin can be installed. **Never loosen the nut to align**

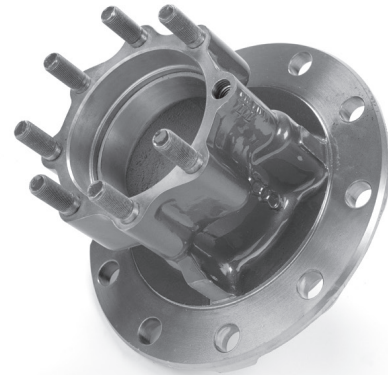
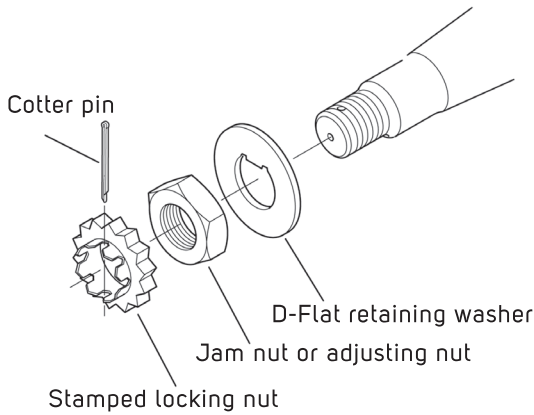

Seal Replacement

In the event the seal on a Gunite High Performance hub becomes damaged and must be replaced, the new seal **MUST** be installed using a seal driver to ensure proper installation with no damage to the seal. If the hub is equipped with a stamped tone ring, care must be taken not to damage the ABS tone ring during this procedure.

ABS Tone Ring Maintenance and Installation

Gunite High Performance hubs are manufactured with either machined-in, powdered metal or stamped ABS tone rings. The tone ring should be carefully checked during the course of routine wheel-end maintenance to ensure proper ABS function during operation. Tone rings should be checked for corrosion or excessive dirt and road contamination build-up. Stamped tone rings should be checked for any damage to the ring itself such as dents and deformities.

If the teeth on a machined-in exciter ring are damaged, the hub **MUST** be replaced immediately to ensure the proper operation of the ABS system.

If the teeth in a powdered metal tone ring are damaged or a stamped tone ring is found to be bent or damaged it **MUST** be removed and a new ring installed **IMMEDIATELY**. The new exciter ring should be installed using the following procedure to ensure proper installation.



Powdered Metal



Stamped Tone Ring



Machined Exciter Teeth

This procedure is to be followed for the installation of either powdered metal or stamped tone rings



Heat the tone ring by submerging it in boiling water or placing it in an oven at 250 degrees for approximately 15 minutes. **Do not heat the tone ring with a torch. This can cause damage to the ring which results in an improper installation and may cause the ABS system to malfunction.**

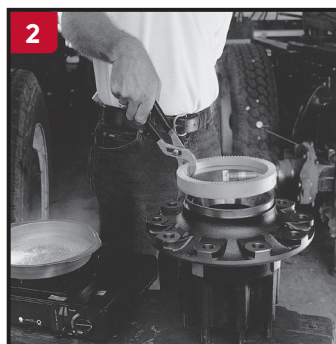

Using pliers, remove the heated tone ring from the water bath or oven and place it onto the machined area of the hub bore.



While the tone ring is still hot, make sure it is properly positioned and use a rubber hammer to carefully tap the ring into place. Make sure that the tone ring is properly seated around the entire circumference.

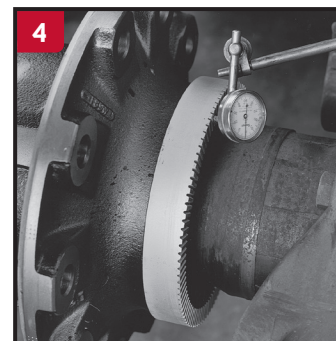

Once the installation is complete; check the tone ring using a dial indicator to make sure it is evenly seated on the hub.

NOTE

If a tone ring must be replaced, it must be replaced with a Gunite tone ring. Gunite tone rings are specifically designed and manufactured to exact tolerances for each hub model. Do not attempt to install a tone ring from another manufacturer. Installing a non-Gunite tone ring may result in improper ABS system operation.

Lubrication Requirements

The following lube recommendations and procedures for the Gunitite High Performance hub are based on "typical" industry standards.

NOTE

Refer to equipment manufacturer for specific temperature service limitations and specific approved grease and oil products recommendations.

All oil lubricants must meet A.P.I. (American Petroleum Institute) specification GL-5. All grease lubricants must meet NLGI (National Lubricating Grease Institute) grade specifications.

WARNING

Do not mix grease with oil. Do not mix a synthetic-base lubricant with a petroleum or mineral-based lubricant. Mixing lubricants can reduce bearing life and potentially cause bearings to fail during operations. When changing the lubricant type or composition, thoroughly clean all internal components and surfaces. Remove all traces of residual lubricant.

WARNING

Do not grease pack bearings on oil lubricated applications. Grease packing bearings in these applications will prohibit oil from entering the bearing as required for proper lubrication during vehicle operation.

Non-drive, Steer Axle Hubs for Dana and Meritor 12,000 to 14,000 Pound GAWR Applications

Install an approved hubcap per the manufacturers recommended practice. Fill the hub with 10 to 12 ounces of approved lubricant or until the oil reaches the maximum fill line or the bottom of the hubcap center plug opening. Allow time for the oil to seep through the outer bearing to the hub cavity or hubcap, depending on fill method used.

Typical lubricants: 75W/90 above -40°F (-40°C) • SAE 50 above -40°F (-40°C)

Drive Axle Hubs for Dana and Meritor 20,000 to 26,000 Pound GAWR Applications

Install the axle shafts per the manufacturers recommended practice. Gunitite High Performance hubs are designed with an integral oil fill port located in the drive flange bolt circle. Remove the hub fill port plug. Fill the hub with 8 ounces of approved axle oil. Reinstall the fill port plug; tighten to 20 - 25 ft. lbs. of torque.

Lubrication of wheel-ends without oil fill port:

1. With the axle level and wheel-ends assembled, add lubricant through filler hole in axle housing cover until fluid is level with the bottom of filler hole.
2. Raise and lower each axle end, holding each end in the raised position for at least one minute to allow lubricant to be evenly distributed throughout the entire axle assembly.
3. Once you have raised each axle end as described in step 2, return the axle to a level position and add lubricant through the housing cover oil filler hole unit until the fluid is level with the bottom of the hole.

Note: Axles without wheel-end fill holes will require approximately 2.5 additional pints of lubricant to bring the lube level even with the bottom of the fill hole.

Typical lubricants: 75W above -40°F (-40°C) to +35°F (-2°C) • 75W/90 above -40°F (-40°C) • 75W/140 above -40°F (-40°C) • 80W/90 above -15°F (-26°C) • 85W/140 above +10°F (-12°C)

Trailer Axle Hubs for Dana and Meritor Applications

Clean the mounting surface of the hub and hubcap. Install the hubcap using a new gasket. Torque the hubcap bolts in a crisscross pattern 8 - 10 ft. lbs. of torque.

Remove the hub or hubcap fill plug. Hub fill capacity depends on the type of axle. With the axle level, fill the hub with the recommended amount of approved lubricant until the oil level reaches the full line on the hubcap. Install the fill plug and tighten to 18 - 20 ft. lbs. of torque.

Note: If you are using synthetic grease, refer to the lubricant manufacturers recommendations.

Dana J/D22 axles and Meritor TN/TQ axles - Fill with approximately 10 to 12 ounces of the following lubricants. When properly filled, the oil should reach the line on the hubcap.

Dana P axles and Meritor T axles - Fill with approximately 18 to 20 ounces of the following lubricants. When properly filled, the oil should reach the line on the hubcap.

Typical lubricants: 75W above -40°F (-40°C) to +35°F (-2°C) • 75W/90 above -40°F (-40°C) • 75W/140 above -40°F (-40°C) • 80W/90 above -15°F (-26°C) • 85W/140 above +10°F (-12°C) • SAE 50 above -40°F (-40°C)

ACCURIDE WHEEL END SOLUTIONS (AWES) LIMITED WARRANTY TO FILE A WARRANTY CLAIM, CALL (800) 869-2275 ext 1

Accuride warrants to the original purchaser or the original end user that its products are free from defects in material and workmanship. The limited warranty time-frame (reference table below) is based on the date of product manufacture and shall be void if the product is altered, modified, misapplied, misused, neglected, repaired or not maintained in accordance with the instructions printed in the product-specific Accuride Safety & Service Manuals⁽²⁾.

GENERAL PRODUCT OVERVIEW

| Product Type | 8 years/ 96 months | 5 years/ 60 months | 2 years/ 200,000 miles ⁽¹⁾ | 1 year/ 12 months |
|---|-------------------------------|---|--|---|
| Accuride Aluminum Wheels ⁽²⁾ | | Industry Standard Aluminum Wheels Duplex [®] Aluminum Wheels ACCU-SHIELD [®] Wheels ACCU-ARMOR [™] Wheels ProShield Black Wheels | Flange Wear on ACCU-FLANGE [™] Wheels | |
| Accuride Steel Wheels ⁽²⁾ | Corrosion Only ⁽⁶⁾ | Extra Service Wheels [™] (ESW) Styled Steel Wheels Tubeless Wheels and Demountable Rims Steel Armor [™] ⁽⁶⁾ | | ProFinish [™] Corrosion Only ⁽⁶⁾ Duplex [®] Steel Disc Wheels Duplex [®] Demountable Rims Tube-Type Wheels & Demountable Rims Light Truck Wheels Steel Bolt-Together Specialty Wheel |

| Product Type | 6 years/ 1,000,000 miles ⁽¹⁾ | 5 years/ 500,000 miles ⁽¹⁾ | 4 years/ 400,000 miles ⁽¹⁾ | 3 years/ 350,000 miles ⁽¹⁾ | 3 years/ 300,000 miles ⁽¹⁾ | 2 years/ 200,000 miles ⁽¹⁾ | Limited Warranty ⁽²⁾ |
|--|--|--|--|---|---|--|-------------------------------------|
| Gunite Slack Adjusters ⁽²⁾ | Over-The-Road/Line Operated Trucks and Trailers ⁽⁴⁾ | Over-The Road/Line Operated Trucks and Trailers ⁽³⁾ | School Bus/City Delivery Vehicles ⁽⁴⁾ | | School Bus/City Delivery Vehicles ⁽³⁾ Severe Service: Garbage/ Refuse Trucks, Fire Trucks, Logging, etc. ⁽⁴⁾ | Severe Service: Garbage/Refuse Trucks, Fire Trucks, Logging, etc. ⁽³⁾ | |
| Gunite Hubs ⁽²⁾ | | TRU-SET [®] Trailer | | TRU-SET [®] Front/Steer TRU-SET [®] Rear/Drive | | | Industry Standard Hubs |
| Gunite Brake Drums ⁽²⁾ | | | | | | | Industry Standard Brake Drums |
| Gunite Disc Brake Rotors ⁽²⁾⁽⁵⁾ | | | | | | | Industry Standard Disc Brake Rotors |
| Gunite Spoke Wheels ⁽²⁾ | | | | | | | Industry Standard Spoke Wheels |

(1) Time or miles, whichever occurs first. Time is measured from date of manufacture.

(2) See Remedies and Limitations of Remedies and refer to appropriate Accuride guide for additional limited warranty condition details: Accuride Rim/Wheel Safety & Service Manual, Gunite Heavy-Duty Brake Drums, Gunite Automatic Slack Adjuster Service Manual, Gunite Disc Brake Rotors Maintenance Manual, and Gunite Disc Wheel Hubs, High-Performance Hubs, Spoke Wheels Maintenance & Installation Manual, and Steel Wheel Refinishing Criteria.

(3) Manufactured prior to April 6, 2015.

(4) Manufactured on or after April 6, 2015.

(5) Limited warranty for life of product.*

* "Life of product" means such period until the product has reached its maximum/minimum brake surface limitation. Product remains subject to the terms and conditions in this limited warranty, including the provisions on additional product warranty criteria and remedies and limitation of remedies.

(6) Designated steel wheels are covered by a limited warranty to be free of "rust damage" from the date of manufacture indicated on the wheel: ProFinish[™] for twelve (12) months, Steel Armor[™] for sixty (60) months. Rust damage is defined as rust sufficient to require refinishing as determined by Accuride in accordance with the most current version of Accuride's technical bulletin W2.043 Steel Wheel Refinishing Criteria. The Steel Armor[™] warranties do not cover, and expressly exclude, rust in the crevice between the disc and the rim. The Steel Armor[™] coating limited warranties herein apply to wheels manufactured by Accuride on or after January 1, 2017.



ACCURIDE WHEEL END SOLUTIONS (AWES) LIMITED WARRANTY TO FILE A WARRANTY CLAIM, CALL (800) 869-2275 ext 1

ADDITIONAL PRODUCT SPECIFIC LIMITED WARRANTY CRITERIA

Wheels and Rims: The warranty shall be void if the product is used with improper tire sizes, inflation pressures, or exceeded load ratings. The warranty shall be void if the product is not properly maintained in accordance with the Accuride Rim/Wheel Safety & Service Manual. The warranty does not cover defects resulting from corrosion except as stated elsewhere in this document, other non-Accuride components, accident, excessive speed or other abnormal or severe operating conditions.

ACCU-ARMOR™, ACCU-SHIELD®, ACCU-FLANGE™, STEEL ARMOR™, PROFINISH™, PROSHIELD XGT™ and PROSHIELD BLACK: Accuride does not cover the following conditions: (i) Any damage in the areas of the mounting surfaces, such as the area under the mounting nuts, the area in contact with hubs or drums and the area in contact with other wheels in dual position, (ii) Any damage due to cleaning, including damage from the use of abrasives, abrasive brushes, steel wool, scouring pads, strong chemicals or corrosion except as stated elsewhere in this document, and/or (iii) Any damage to the wheel finish due to wheel/tire assembly, removal, balancing weight, misuse, or chipping, whether by contact with road obstacles such as stones, gravel, curbs, barriers, signs, tire changing equipment or otherwise. ACCU-SHIELD®, PROSHIELD XGT™ and PROSHIELD BLACK products are not covered for corrosion. ACCU-FLANGE® products, after washing, can have wheel polish or carnauba wax applied with a 100% cotton cloth. The STEEL ARMOR™ warranties are void with respect to, and expressly exclude, all wheels that have been refinished or refurbished and, for wheels used without an Accuride Wheel-Guard®, the disc face and any other areas impacted by this failure. The STEEL ARMOR™ and PROFINISH™ warranties expressly exclude and do not cover (a) paint appearance, paint integrity, or paint adhesion to the wheels due to chipping effect and (b) corrosion in the crevice between the wheel disc and rim. Accuride recommends cleaning wheels with mild soap and water.

Standard Brake Drums, Spoke Wheels, Disc Wheel Hubs, Automatic Slack Adjusters, and Hardware: The above warranty shall be void if (i) any goods have exceeded Accuride's acceptable wear limits or have been subjected to accidents or abnormal conditions of use, temperature, moisture, dirt or corrosive matter, or (ii) the product fails as the result of another manufacturer's product. The TRU-SET® disc wheel hub requires the use of a seller-approved hubcap and lubricant.

REMEDIES AND LIMITATIONS OF REMEDIES

In the event of any material breach of the above limited warranties, Accuride agrees to repair or replace,* at its sole option, without charge any and all of its warrantable product that fail during normal use and service due to defects in material and/or workmanship, all subject to the original purchaser providing written notice of the alleged breach within 30 days of failure. Time is of the essence herein, and original purchaser's failure to provide written notice to Accuride within the required time of any alleged breach of the foregoing warranty will release and discharge Accuride from any obligation or liability for that breach of warranty. In no event will Accuride be liable for any other costs associated with the replacement or repair of product covered under this warranty, including labor, installation or other costs incurred by customer.

* - NOTWITHSTANDING THE ABOVE, THE SOLE REMEDY UNDER THE STEEL ARMOR™ WARRANTIES SHALL BE THE PAYMENT OF US \$35 FOR STEEL ARMOR™ OR THE REPAIR OR REPLACEMENT OF THE WHEEL (AT ACCURIDE'S SOLE OPTION) IF A WARRANTABLE PRODUCT FAILS DURING NORMAL USE AND SERVICE DUE TO DEFECTS IN MATERIAL AND/OR WORKMANSHIP. Only one claim per wheel may be paid under the Steel Armor™ warranties. The remedy described in this paragraph is Accuride's sole and exclusive obligation under these warranties and in no event will Accuride be liable for special, incidental or consequential damages. Customer must timely report the breach of warranty and demonstrate warrantability under the then applicable procedures during the warranty period. The remedies set forth herein shall be the sole and exclusive remedies available to the original purchaser so that Accuride repair, replacement, or payment as described above is a fulfillment of all Accuride obligations. Accuride SHALL NOT BE LIABLE FOR ANY CONSEQUENTIAL OR INCIDENTAL DAMAGES OF ANY KIND. FURTHER, UNDER NO CIRCUMSTANCE SHALL ACCURIDE BE LIABLE FOR DAMAGES BEYOND THE PRICE OF THE GOODS PURCHASED BY THE ORIGINAL PURCHASER, WHETHER IN CONTRACT, IN TORT OR UNDER ANY WARRANTY OR OTHER USE.

Accuride reserves the right to require product return and/or washing (as previously noted) prior to warranty assessment as a condition of eligibility for warranty remedies. Product return expense must be paid by the product owner and if the product is found warrantable, reasonable freight expenses may be reimbursed by Accuride. No goods are to be returned to Accuride without a Returned Goods Authorization (RGA). If Accuride determines that any of the returned goods are non-warrantable, Accuride reserves the right to charge the original purchaser for the recovery of all transportation costs and expenses incurred in examining, processing and handling such goods. Any controversy or claim that customer may wish to bring that is arising out of or related to this limited warranty or breach hereof must be commenced in writing within 30 days of notification of warrantable status or shall be deemed to be waived.

Any product deemed non-warrantable is the property of the original purchaser and can be returned to the original purchaser upon its request and at its sole cost and expense. Should the non-warrantable item(s) not be reclaimed, Accuride will disposition the product no sooner than 30 days after original purchaser notification has been made.

For all warranty related questions, please contact your Accuride warranty administrator at (800) 869-2275 Option 1 or submit questions or claims to warrantyadmin@accuridecorp.com.

THE ABOVE WARRANTY IS THE SOLE AND EXCLUSIVE WARRANTY GIVEN BY ACCURIDE AND IS IN LIEU OF ALL OTHER WARRANTIES EXPRESSED, STATUTORY OR IMPLIED, INCLUDING WARRANTIES OF MERCHANTABILITY AND FITNESS FOR A PARTICULAR PURPOSE, ALL OF WHICH ARE EXPRESSLY DISCLAIMED BY ACCURIDE. IN NO EVENT SHALL THIS WARRANTY BE DEEMED TO COVER INCIDENTAL, SPECIAL, INDIRECT OR CONSEQUENTIAL DAMAGES OF ANY KIND.

Your single source for industry-leading wheel end solutions.

STEEL & ALUMINUM WHEELS | DRUMS | HUBS | ROTORS | SLACK ADJUSTERS

For more information: **(800) 823-8332** | accuridecorp.com

Gunite | 302 Peoples Avenue | Rockford, IL 61104-7092

